

## Quick Release Couplings

### SPECIFICATION

#### Types

- Type **A**: With threaded stud
- Type **I**: With internal thread

#### Coding

- **F**: Fixed bearing
- **L**: Floating bearing

#### Housing

Aluminum

Black anodized **ASS**

Closure mechanism

Steel, tempered

Zinc plated, blue passivated

Fastening bushing (type I)

Stainless steel AISI 431

Tempered

Mounting screw (type A)

Socket cap screw DIN 7984

Property class 8.8

Other screws

Steel, zinc plated, blue passivated

Other parts

Stainless steel

Operating temperature -30 °C to 120 °C

### INFORMATION

Quick release couplings GN 1050 position and connect components without tools using studs GN 1050.1 (see page ) for a tight and repeatable fit. For repeated machine set ups or assemblies that require the inconvenient use of a screwdriver, quick release couplings can be used on fixtures or production lines to efficiently mount guide rails, covers or additional devices.

A safety locking button protects against accidental opening of the coupling. When pressing the button, the sleeve can be moved axially to unlock a stud inserted into the notch on the inside. At the same time, a red ring becomes visible on the outside to indicate the unlocked state.

The couplings do not transmit any torque. If multiple couplings are used on the same unit, coding L can be used to compensate for a radial and axial offset. The bores  $d_4$  can hold cylinder or cam point pins to position the coupling, if needed. For coding L, the pin holes on the application must be proportionally larger to allow for radial adjustments.

Flanges GN 1050.2 (see page ) are available as an accessory for the assembly of couplings and studs, and provide additional attachment options.



### ACCESSORY

- Studs GN 1050.1 (see page )
- Flanges GN 1050.2 (see page )

### ON REQUEST

- Other colors (anodized) or plain

### TECHNICAL INFORMATION

- Stainless Steel characteristics (see page A26)
- Strength values of screws / nuts (see page A20)

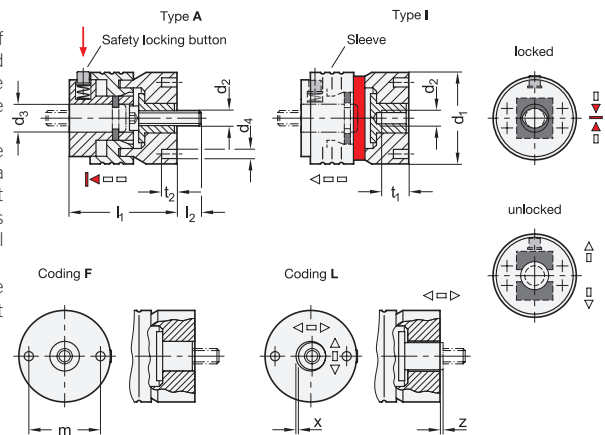

### GN 1050

Description	Nominal size	d2	d1	d3 Bore ±0.03	d3 Studs GN 1050.1 ±0.03	d4 H7	l1	l2	m	t1 Min.	t2	x +0.05 Radial offset	z ±0.1 Axial offset	
GN 1050-2N-M10-A-F-ASS	2N	M 10	53	18.5	18.25	6	70.1	15	40	-	10	-	-	430
GN 1050-2N-M10-A-L-ASS	2N	M 10	53	18.5	18.25	6	70.1	15	40	-	10	0.75	0.4	397
GN 1050-2N-M12-A-F-ASS	2N	M 12	53	18.5	18.25	6	70.1	20	40	-	10	-	-	437
GN 1050-2N-M12-A-L-ASS	2N	M 12	53	18.5	18.25	6	70.1	20	40	-	10	0.75	0.4	390
GN 1050-2N-M10-I-F-ASS	2N	M 10	53	18.5	18.25	6	70.1	-	40	18	10	-	-	407
GN 1050-2N-M10-I-L-ASS	2N	M 10	53	18.5	18.25	6	70.1	-	40	18	10	0.75	0.4	404
GN 1050-2N-M12-I-F-ASS	2N	M 12	53	18.5	18.25	6	70.1	-	40	18	10	-	-	403
GN 1050-2N-M12-I-L-ASS	2N	M 12	53	18.5	18.25	6	70.1	-	40	18	10	0.75	0.4	397

### Mounting and load information

GN 1050 (Type A) with GN 1050.1 (Type A)

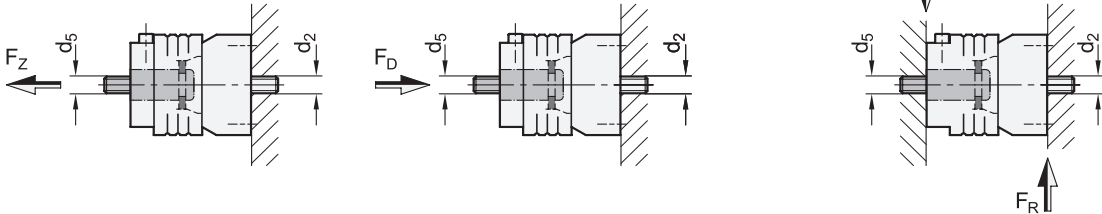

GN 1050 (Type I) with GN 1050.1 (Type I)

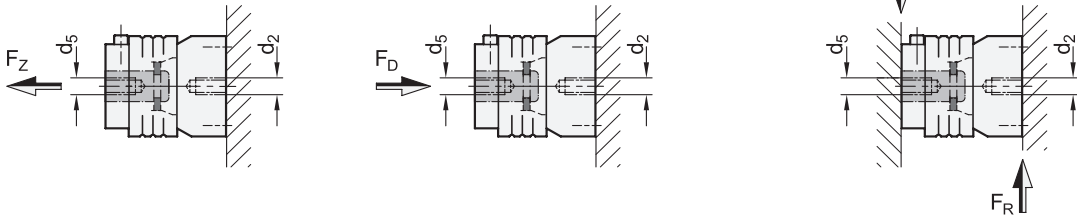

Nominal Size	d2 Mounting thread Quick release couplings	d5 Mounting thread Studs GN 1050.1	Fz Max. tensile load in kN	Fd Max. compressive load in kN	FR Max. shear load in kN
2N	M 10	M 10	25	25	19
2N	M 10	M 12	25	25	19
2N	M 12	M 10	25	25	19
2N	M 12	M 12	35	35	28

**Safety instructions:** The load capacities can only be achieved if the surrounding structure is capable of supporting these loads. Any threaded holes on the application or inserted nuts and screws require at least property class 8. Depending on the application, additional safety factors should be added.

### Application example for profile systems

